

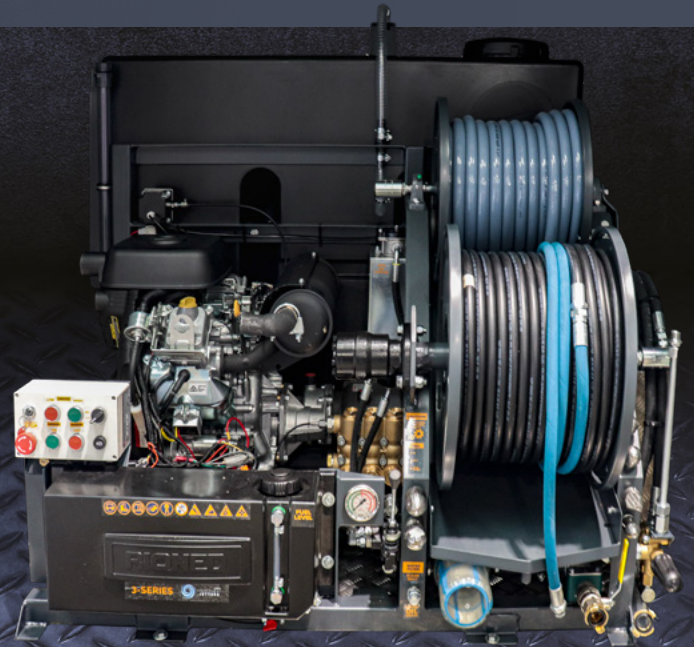

by **Rioned.**
**ANDY GUEST
JETTERS**

3-SERIES DRAIN DRAIN JETTER

TECHNICAL INFORMATION, DIMENSIONS & UPGRADES

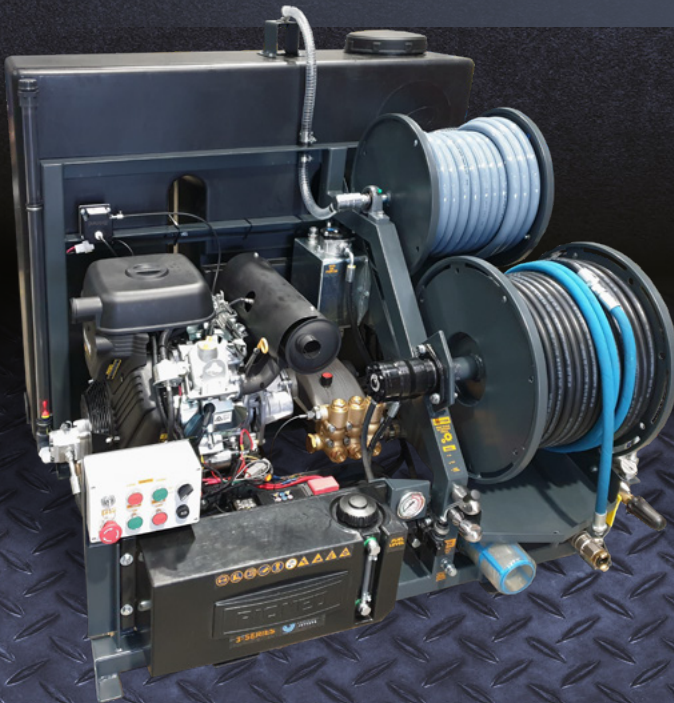

andyguestjettters.co.uk



3-SERIES VAN-PACK JETTER

The 3-Series is a petrol-driven jetter that offers the perfect balance of performance and functionality within a compact and lightweight frame.

Suitable for use in sewers and drains up to $\varnothing 300\text{mm}$, the 3-Series is a Stage V emissions-compliant machine utilising a modern, powerful engine that is lighter, quieter and more cost-effective to operate than diesel-engine machines with similar characteristics. Until recent years, this type of jetter specification and

level of performance was unavailable to operators with smaller commercial vehicles.

While it's true that petrol engines run hotter than diesels, and there remains some scepticism about them in the industry, the 3-Series dissipates residual engine heat quickly. The EFI engine also has a better torque curve, which maximises performance and efficiency, and the engine management system improves diagnostic capabilities and allows for engine remapping if required.

The 3-Series is feature-rich and includes an electronic push-button control panel for ease of operation. Due to its compact size, the 3-Series can be installed into almost any commercial vehicle.

With an industry-standard performance of 3000psi @ 12gpm, the 3-Series more than meets the demands of the professional contractor, and is also designed for single-user operation through the use of a 5-Channel Radio Remote Control. Stack and split system arrangements are also available.

The high-performance petrol jetter with all the characteristics of a diesel powered machine

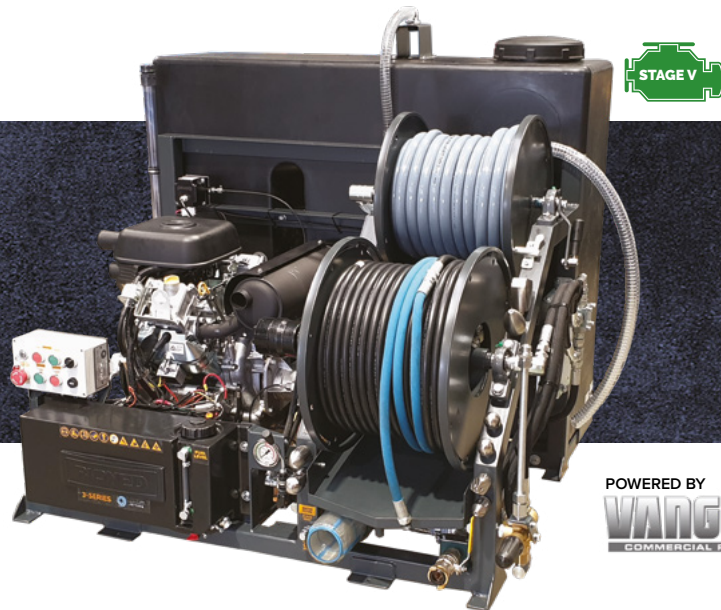

3000psi @ 12gpm

POWERED BY
VANGUARD
COMMERCIAL POWER



FLEXIBLE FINANCE

A range of finance options are available to help spread the cost of the jetter, the vehicle, interior conversions and additional equipment.

TECHNICAL SPECIFICATION

Pipework Diameter	250 – 300mm
Performance	3000psi @ 12gpm (200bar @ 55 lpm)
Std Water Tank Capacity	400 Litres (88 Gallons)
Engine	Briggs and Stratton Vanguard EFI V-Twin Petrol Engine
Engine Power	37hp (27kW)
HP Pump Type	Triplex Plunger Pump
Engine Cooling	Air-Cooled
Run Dry Protection	Standard
Frost Protection	Anti-Freeze Valve
HP Reel	Hydraulic Drive
Hose	80 Metres ½” Lightweight Single-Wire Jetting Hose
Reel Arrangement	Fixed Hose Reel
Filling Hose	25m Reel
Control Box	Electronic Control Panel
Pressure Relief System	Unloader Valve
Remote Control	5-Channel Radio Remote System (Optional)
Construction	Compact Mild Steel, Shot Blasted, Powder Coated
Accessories Included	2 Standard Nozzles, User Manual, Leader Hose, Lightweight Engine and Pump Cover
Approx. Dry Weight	395kg
Approx. Max Weight	750kg (with Standard Water Tank)
Dimensions (mm)	1230mm D x 1250 W x 1200 H (with standard water tank)
Fuel Tank Capacity	15 Litres
Base Vehicle Suitability	Ford Transit Connect, Vauxhall Combo/Vivaro, Mercedes Benz Citan, VW Caddy/Transporter, Renault Trafic, Peugeot Expert

UPGRADES + OPTIONS

- Tank Capacity Upgrade (500, 650 or 800 Litres)
- Speck HP Pump Upgrade
- 5-Channel Radio Remote Control
- Hose Guidance
- Run Dry Protection
- Lightweight Jetting Hose
- Mini Hose Kit
- Safety Lance and Dry Shut Lance
- Specialist Nozzle Kits
- Surface Cleaning Equipment

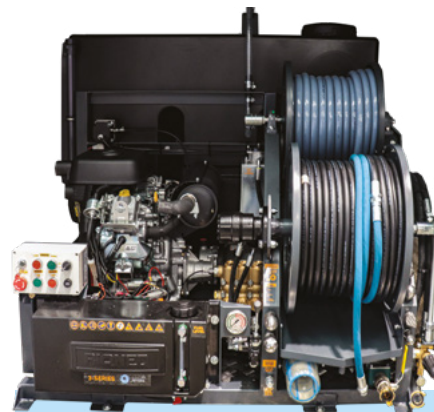

“The performance is exceptional. Its not only lighter and more fuel efficient, but compares to well to diesel-powered machines.”

Danaher and Walsh Group

3-SERIES DIMENSIONS

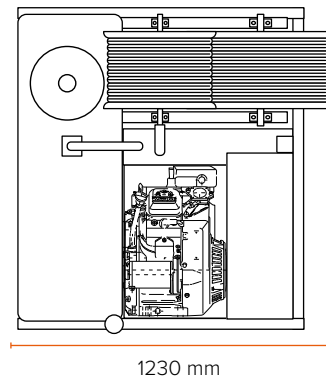
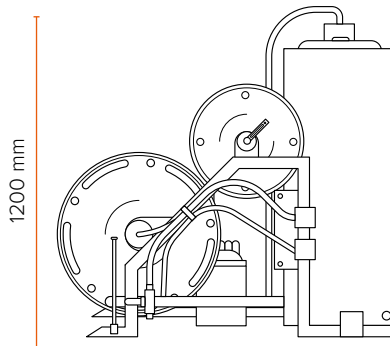
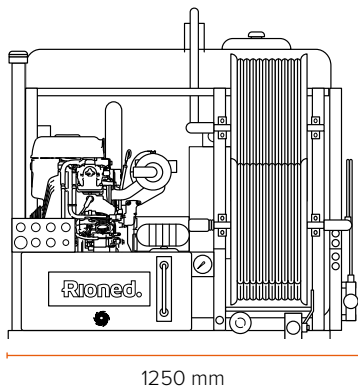

3-SERIES SPECIFICATION

3-Series Width	1250 mm
3-Series Height	1200 mm
3-Series Depth	1230 mm

EXAMPLE VAN:

FORD CUSTOM VAN L2H2

Width between Arches	1351 mm
Vehicle Length	5340 mm
Vehicle Height	2300 mm
Vehicle Width	1986 mm
Load compartment Length	2921 mm
Load compartment Height	1778 mm
Load compartment Width	1775 mm

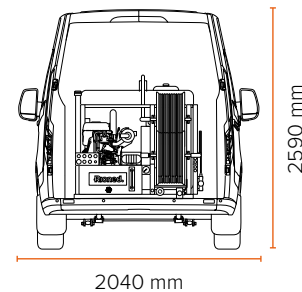
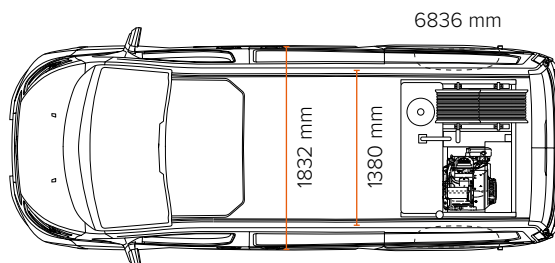
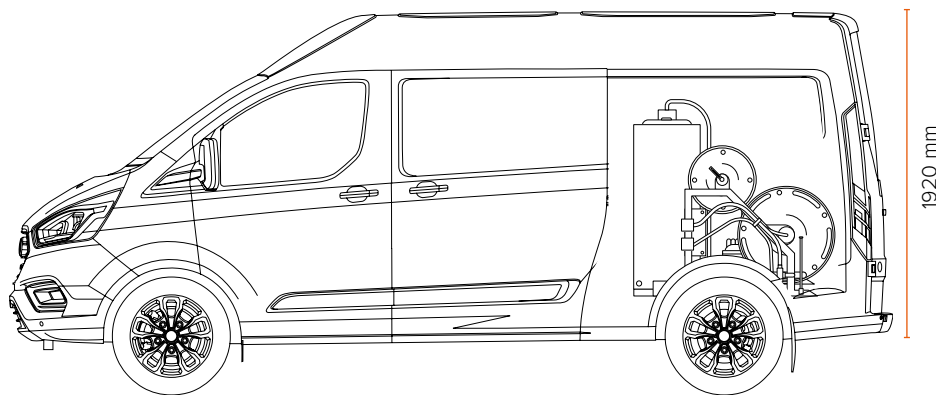

MANUFACTURING SALES + SERVICE



by Rioned.
ANDY GUEST
JETTERS

ANDY GUEST JETTERS

Tel: 03300 240404
sales@andyguestjettters.co.uk
www.andyguestjettters.co.uk

Unit 11, Riparian Way
The Crossings Business Park
Cross Hills, Keighley, West
Yorkshire BD20 7BW

Rioned.

RIONED UK

Tel: 03300 240404
sales@rioned.co.uk
www.rioned.co.uk

FreeFlow House
Stephenson Way
Thetford, Norfolk
IP24 3RU



SERVICE AGENTS

KENSWAY ENGINEERING

Unit 5 Dotton Farm
Sidmouth
Devon EX10 0JY
Tel: 0139 556 7374

CRUMLIN PLANT SALES

90a Blackisland Road
Craigavon
Portadown, BT62 1NH
Tel: 0283 885 2540

SCOTJET LIMITED

50 Loanbank Quadrant
Glasgow
Lanarkshire G51 3HZ
Tel: 0141 440 0200

HP PUMP SERVICES

Wynford Industrial Park
Romsey
Hampshire, SO51 0PW
Tel: 01794 367 477

N1 JETTING SYSTEMS

Unit 13 Cathedral Park
Durham DH1 1TF
Tel: 0191 375 77790

HYDRO-POWER UK LTD

Robell Way
Water Lane Industrial Estate
Storrington (Nr. Pulborough)
West Sussex, RH20 3DW
Tel: 01903 741780

TECHNICAL CAMERA SERVICES LIMITED

Drumnacarta, Snugboro
Castlebar, Co. Mayo F23 KW90
Tel: +353 871627963

MIDLAND JETTING SERVICES LTD

Unit 4, Kingfisher Industrial
Estate, West Bromwich B70 0AT
Tel: 0121 520 6641

We also offer export sales via a worldwide network of agents.

andyguestjettters.co.uk

